

PARÇA KODU PART CODE	PARÇA ADI PART NAME	s ÖLÇÜSÜ (KALINLIK) s MEASURE (THICKNESS)	Malzeme Material	Kaplama / Coating		
				SN	AG	Nİ
TEK 2855 RP	PUNTA UCU 2 =RP=	-----	(CuZn30) Pirinç / Brass	-	-	-
TEK 2855 RPK	PUNTA UCU 2 =RPK=	-----	(CuZn30) Pirinç / Brass	+	-	-
TEK 2855 RÇN	PUNTA UCU 2 =RÇN=	-----	Nikel kaplı çelik / Nickel plated Steel	-	-	+
TEK 2855 RPT	PUNTA UCU 2 (ters sarım) =RP=	-----	(CuZn30) Pirinç / Brass	-	-	-
TEK 2855 RPKT	PUNTA UCU 2 (ters sarım) =RPK=	-----	(CuZn30) Pirinç / Brass	+	-	-

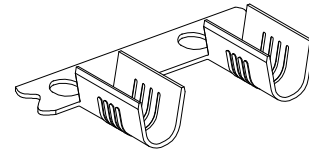
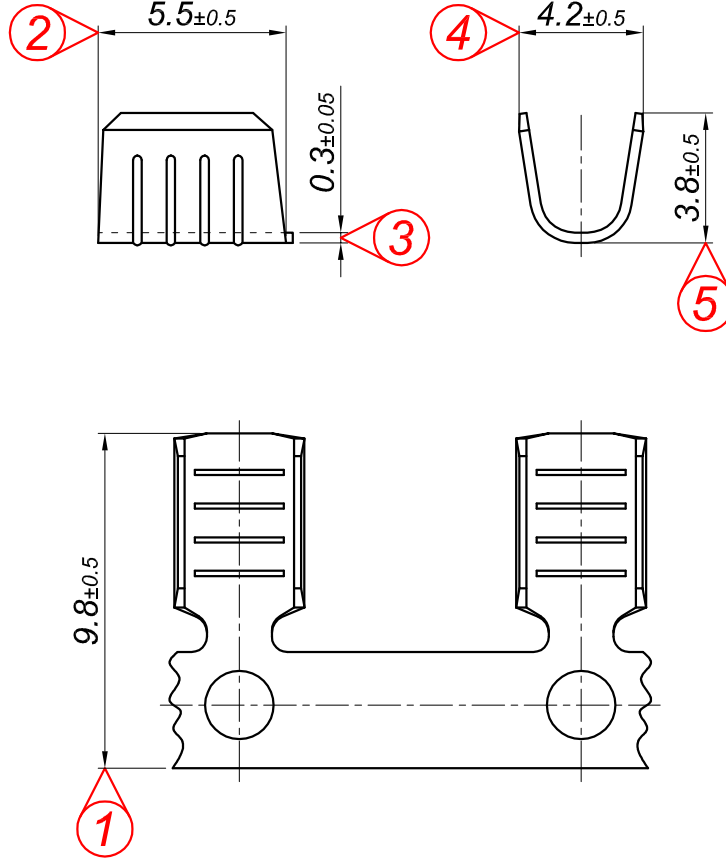

Perspektif
Perspective

Kalıp çıkış yönü
Mold output direction

Makara açılım yönü
Reel opening direction

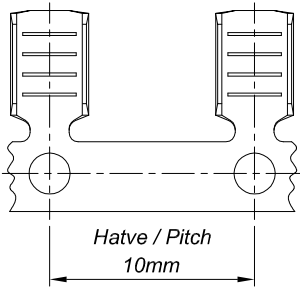

Ölçek
Scale : 3 / 1

Kablo Kesiti
Wire Section : 0.5 - 2 mm²

Resmin Üzerinden Ölçü Almayınız
Don't use the drawing for measuring purpose

Tarih / Date	07.11.2013	İmza /Signature	Ölçek / Scale		
Çizen / Desing	M.Yağcı				
Onay / Approval	S.Gölcük		5 / 1	No	Değişiklik / Revision
					Tarih/Date
	Parça Adı: Part Name	PUNTA UCU 2		Parça Kodu: Part Code	TEK 2855